

Explorer Prime

Game Rules

2025

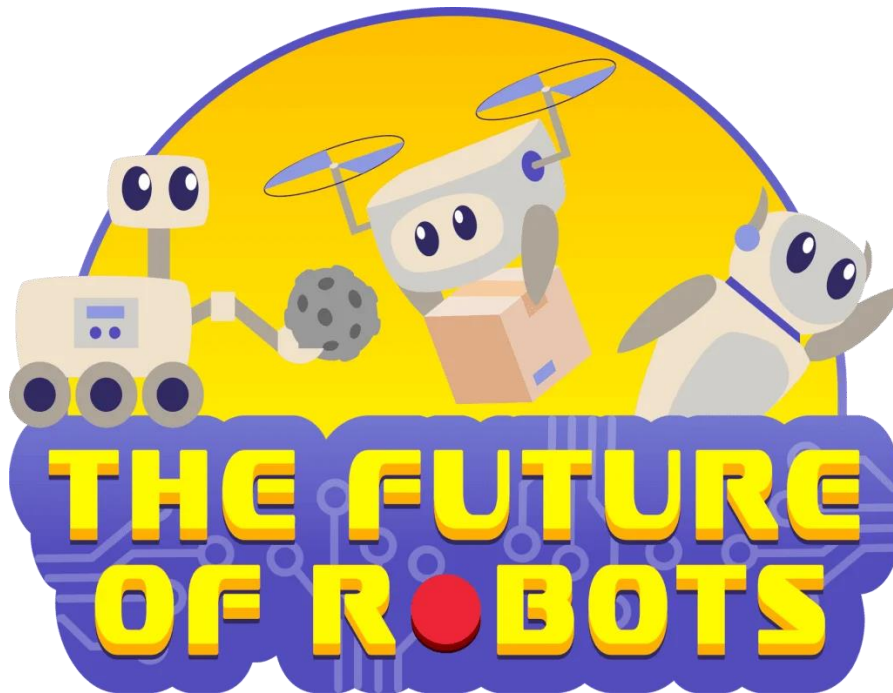

Date: 31 January 2025

Table of Contents

PART ONE – GAME DESCRIPTION	1
1. Introduction	1
2. Game Field	2
3. Game Objects, Positioning, Randomization	3
4. Robot Missions	9
5. Scoresheet	11
6. Scoring Interpretation	12
PART TWO – ASSEMBLY OF GAME OBJECTS	18

PART ONE – GAME DESCRIPTION

1. Introduction

The Explorer Prime competition is for children from the ages of 11 years to 16 years in the year of the competition and not the child’s age at the time of the competition. The Explorer Competition is developed in South Africa and has no international component. In some years depending on national organiser decisions, there will be official provincial and national events.

For the 2025 Explorer season, provincial organisers have been given the choice to run a physical WRO Explorer event depending on demand from registrations in the province. The WRO National Organising Committee will later in the year make a decision as to the likelihood of a physical Explorer National Event.

The Explorer mat for 2025 uses the Junior RoboMission game mat Mars Exploration.

Please check the website www.wrosa.co.za for the latest event updates.

Game Story

You have been tasked with designing and programming a robot that will assist unmanned operations on the Martian surface. Your robot is crucial in the construction of the Mars habitats and terraforming of the planet before the first humans arrive. Your robot must work efficiently and carefully on the Martian surface, a wrong move may cause the whole mission to be aborted, valuable resources and time may be lost. You will need to move delicate, equipment, offload shuttles, mine and deliver valuable ores and maintain the algae tanks producing the crucial oxygen needed for the successful terraforming of Mars for human habitation.

Good luck team, think creatively, plan accordingly and have fun as you complete this Martian Mission.

2. Game Field

The following graphic shows the game field with the different areas and elements.

If the table is larger than the game mat, place the mat on the wall with the start area side touching the table wall.

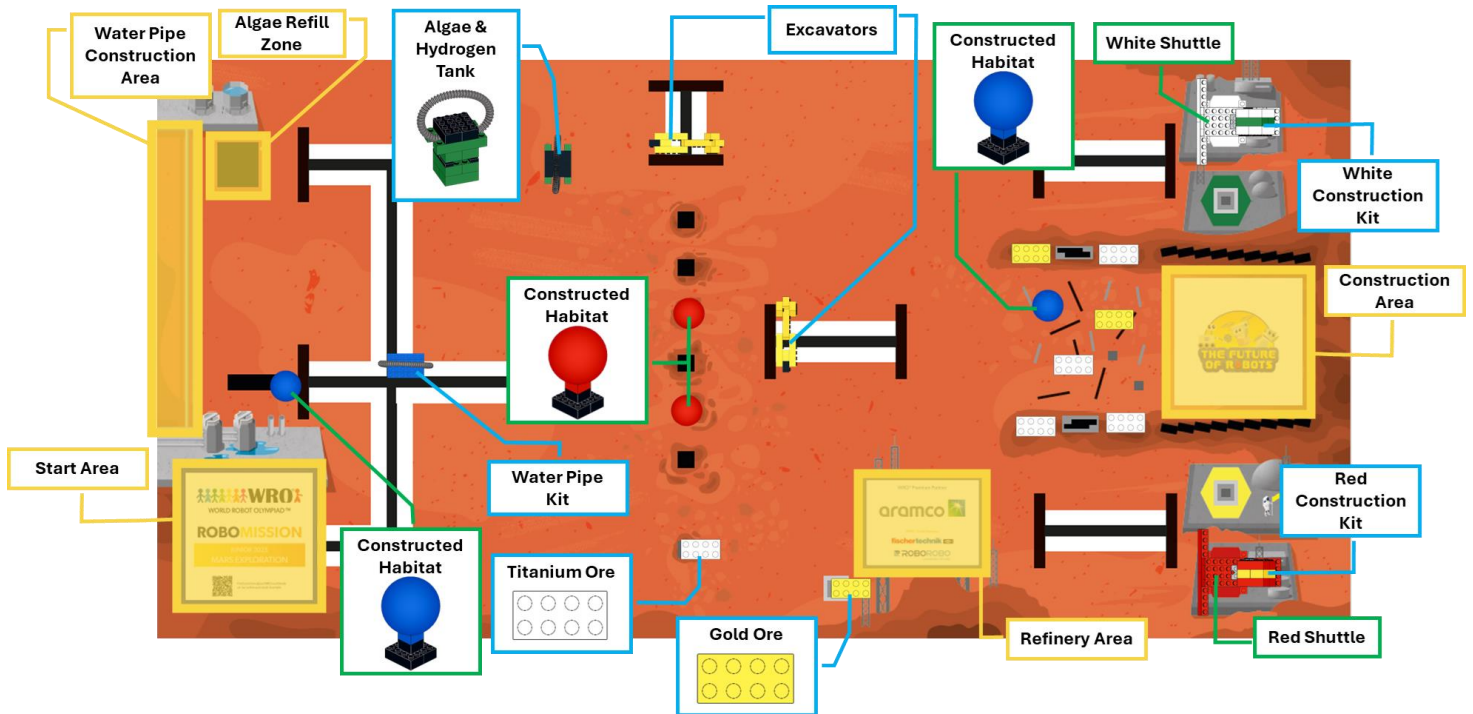

Quick Summary of Tasks:

1. Use the Ultrasonic Sensor to start the robot moving.
2. Use the light sensor to follow a line.
3. Move the excavators completely onto the mars surface. (must remain upright)
4. Move the water pipe kit to the water pipe area.
5. Move the algae growth tank to the algae refill zone.
6. Red and White Construction Kits are touching the game mat.
7. Red and White Construction Kits moved completely inside the Construction Area.
(Shuttles are still in their starting position and undamaged)
8. Gold and Titanium Ore deposits moved into the refinery area.
9. Robot projects/touches into the finish area.
10. Hydrogen tank is still in its starting position.
11. Constructed Habitats are not damaged. (balls not touching the game mat)

Note: If an element is damaged or broken no points can be scored for that element.

3. Game Objects, Positioning, Randomization

Excavators (x2)

Two excavators have been placed on the game mat. One above the refinery area, the other to the right of the algae tank.

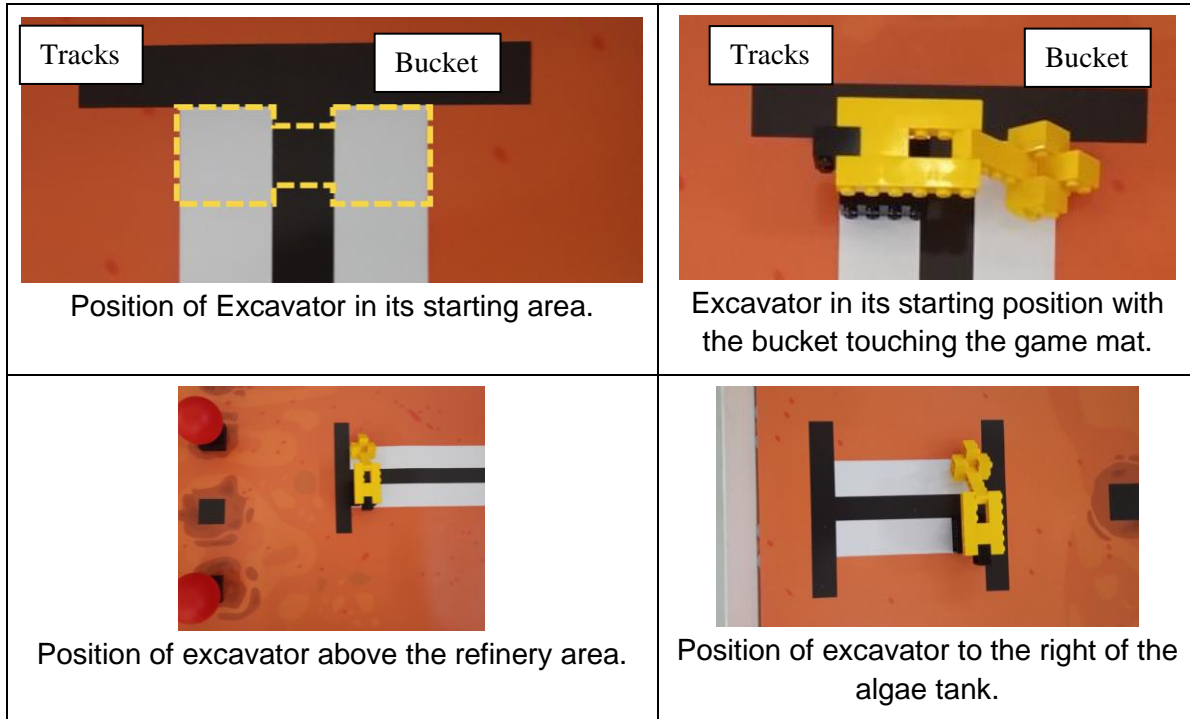

Water Pipe Kit (x1)

One water pipe kit is placed to the right of the main intersection on the game mat.

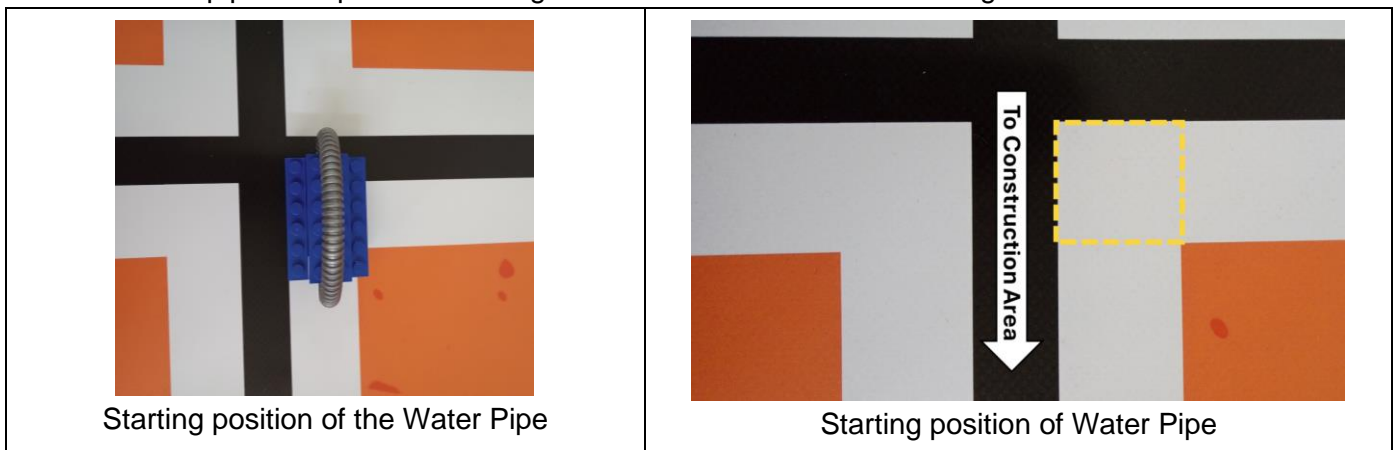

Titanium (x5) & Gold (x3) ore deposit starting positions

Five titanium (white 2x4 bricks) and three gold (yellow 2x4 bricks) ore deposits are placed on the game mat. One titanium ore deposit is placed in position 1, position 1 will always hold a titanium deposit. The remaining positions 2 to 8 are **randomised** at the start of the competition day and will remain the same for the day's competition.

To randomise place the remaining 4 titanium and 3 gold elements into a bag/pocket. Draw out one brick starting from position 2 through to 8 until all bricks are on the game mat.



One possible starting position of the Titanium and Gold ore elements.

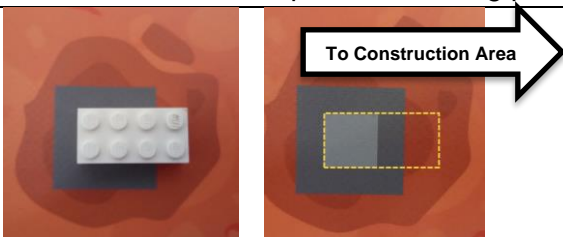

Position of Titanium (white 2x4 brick) in position 1
Will always be a titanium ore deposit

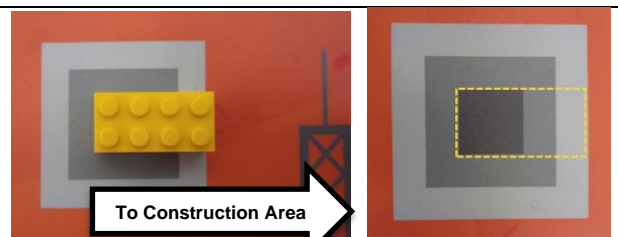

Position of Gold ore deposit (yellow 2x4 brick) in position 2
This element is part of randomisation

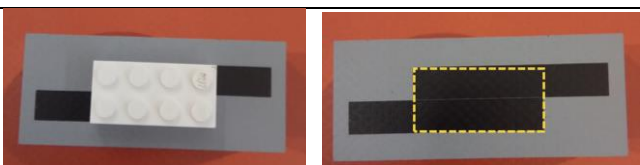

Ore deposit placement in the large grey rectangles
These elements are randomised

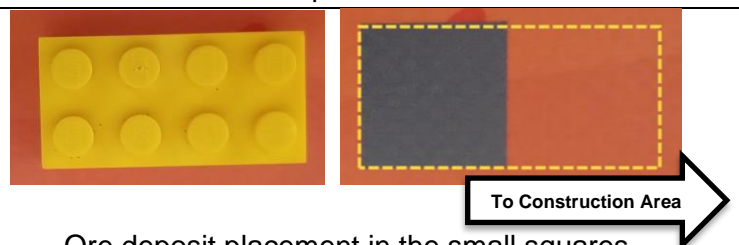

Ore deposit placement in the small squares
These elements are randomised

Water Pipe Kit (x1)

One water pipe kit is placed to the right of the main intersection on the game mat.

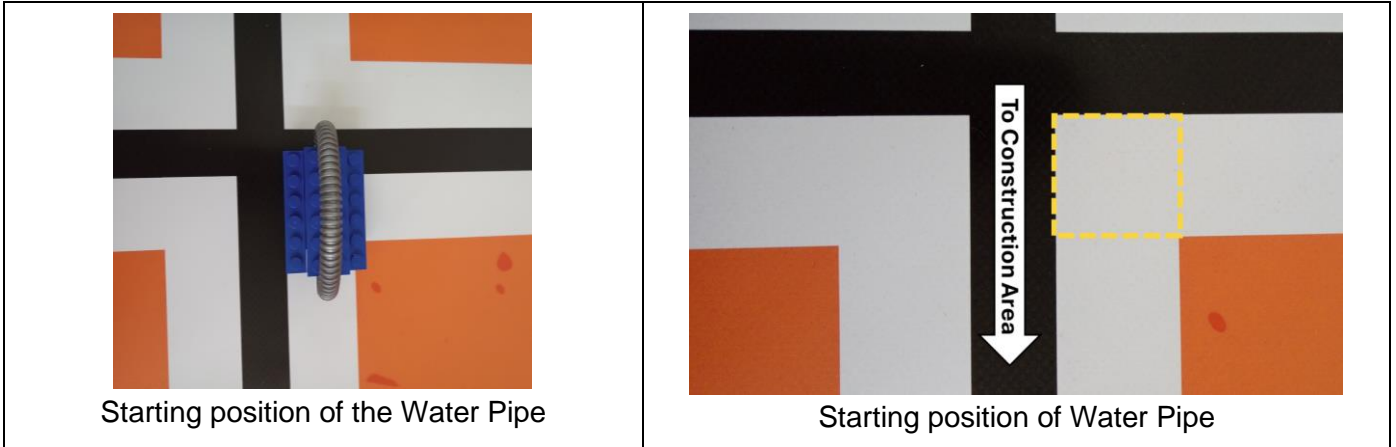

Starting position of the Water Pipe

Starting position of Water Pipe

Algae Tank (x1) & Hydrogen Tank (x1)

One algae tank is placed on the game mat to the left of the excavator furthest from the start area.

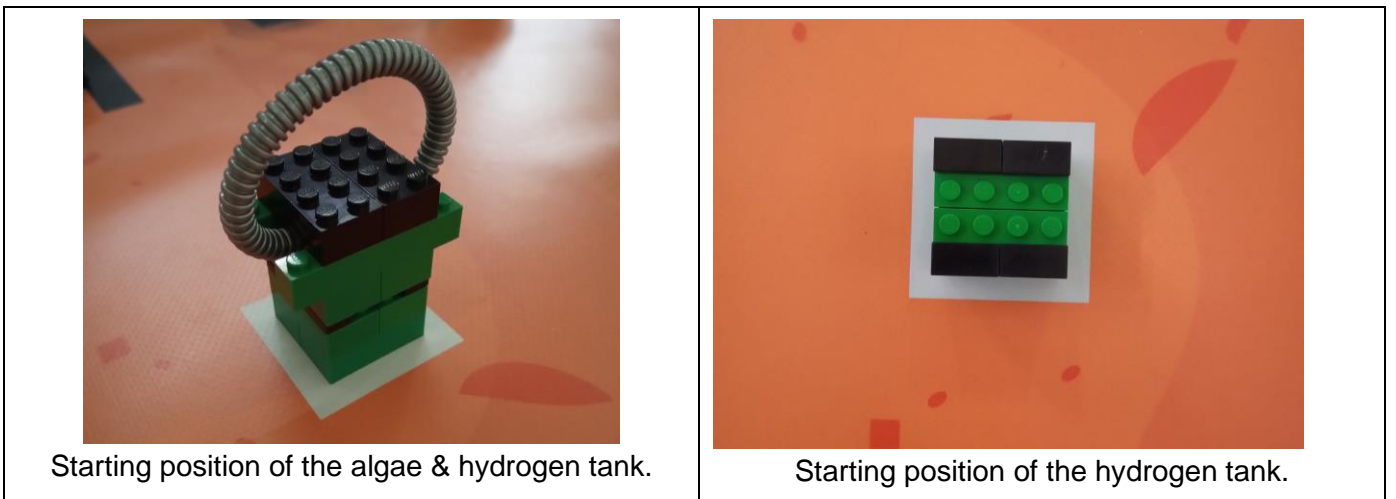

Starting position of the algae & hydrogen tank.

Starting position of the hydrogen tank.

Red Shuttle (x1)

One red shuttle is placed on the game mat carrying the red construction kit. The red shuttle is placed in the red area bottom right of the game mat.

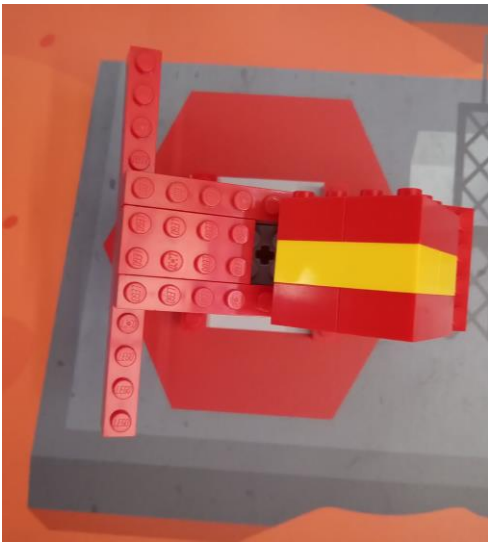

Red shuttle starting position
Red construction kit is placed on the shuttle with the studs facing the construction area.

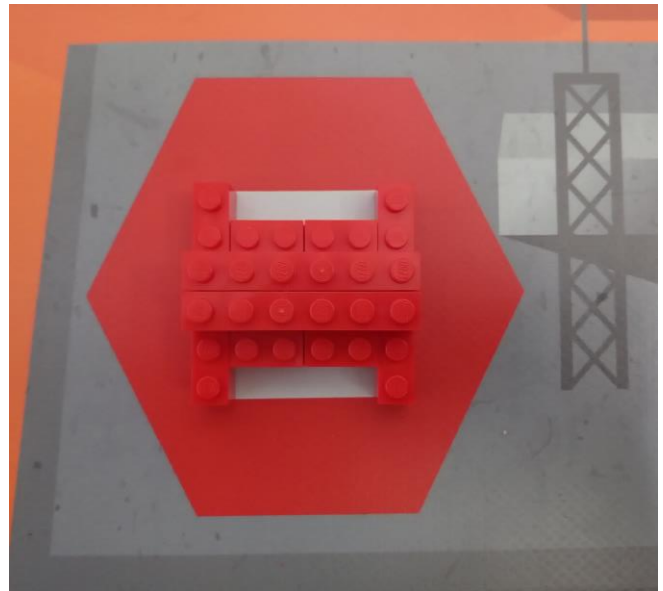

Placement of the red shuttle element base in its starting position.

Position of the red construction kit on the red shuttle.



Correct position of the red construction kit



Wrong position of the red construction kit



Wrong position of the red construction kit



Wrong position of the red construction kit

White Shuttle (x1)

One white shuttle is placed on the game mat carrying the white construction kit. The white shuttle is placed in the white area in the top right of the game mat.

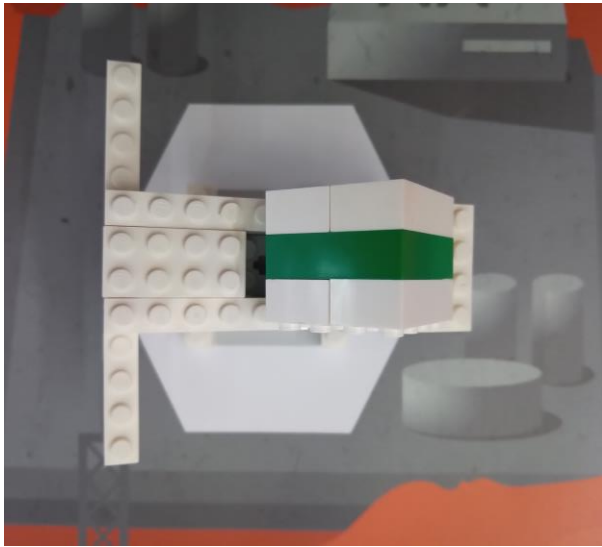

White shuttle starting position

White construction kit is placed on the shuttle with the studs facing the construction area.



Placement of the white shuttle element base in its starting position.

Position of the white construction kit on the red shuttle.

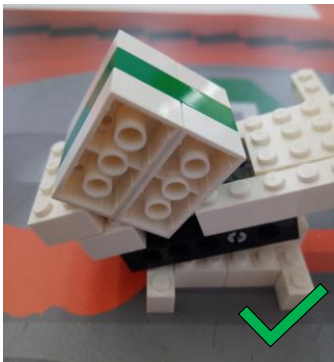

Correct position of the white construction kit



Wrong position of the white construction kit



Wrong position of the white construction kit



Wrong position of the white construction kit

Constructed Habitats (x4)

There are four constructed habitats placed on the game mat. Two habitats have red balls placed on top of the pedestal base and two habitats have blue balls placed on top of the pedestal base. One habitat is placed above the starting area on the black rectangle. One habitat is placed on the second black square closest to the start area, one habitat is placed on the fourth black square closest to the start area. One habitat is placed on the small square near the ore deposits.



Placement of habitat one closest to the start area.



Placement of habitat two on the second black square closest to the start area.



Placement of habitat three on the fourth black square closest to the start area.



Placement of the habitat in the ore deposit area.

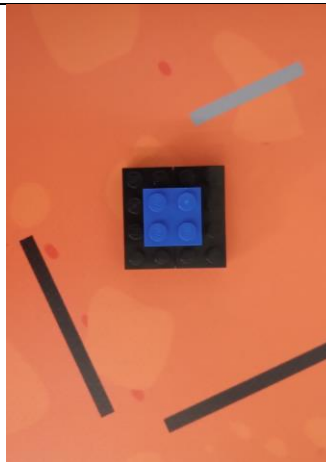

Placement of the habitat base in the ore deposit area.

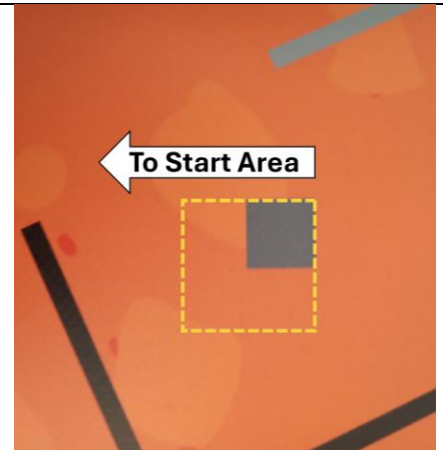

Placement of the habitat base in the ore deposit area.

4. Robot Missions

4.1 Points for use of sensors

Teams should program their robot so that when a team member or judge breaks the ultrasonic sensors beam the robot waits for 1 second and then begins moving out of the start area before completing any of the missions on the game table. (if a judge can't verify this on the game mat, they must check the team's program)

Teams should program the colour/light sensor, so the robot follows a line of any colour anywhere on the game mat. (if a judge can't verify this on the game mat, they must check the team's program)

4.2 Move the excavators

Two excavators have been placed on the game mat. Move the excavators from their starting positions onto the Martian soil. The excavators must completely touch the Martian surface and no other images. The excavators must remain upright and undamaged for points to be awarded.

4.3 Mine the ore deposits

The robot must collect the titanium and gold ore deposits and deliver them to the refinery area. Full points are awarded if the ore is completely inside of the refinery area (white area). Partial points are awarded if the ore is not completely inside of the refinery area (touching the grey outside border and the inside scoring area). The ore can be placed in any orientation.

4.4 Deliver the water pipe kit

The robot should collect the water pipe kit and deliver it to the water pipe construction area. The water pipe kit should be completely inside the water pipe construction area (area past the grey pipe images). Partial points are awarded if the water pipe kit is not completely inside the water pipe construction area (touching the grey water pipe images)

4.5 Refill the algae tank

The robot should collect and deliver the algae tank from on top of the hydrogen tank to the algae refill zone. The algae tank should be placed completely inside the algae refill zone and must remain upright for full points to be scored. Partial points are awarded if the algae tank touches the algae refill zone or is not placed upright in the algae refill zone.

4.6 Don't move the hydrogen tank

The hydrogen tank must remain in its starting position. The element **must not touch** the game mat outside of its grey starting square.

4.7 Offload the shuttles

Your robot should offload the red and white shuttle and deliver the construction kits to the construction area. Points are awarded if the construction kit touches the game mat and is no longer on a shuttle. Further points are awarded if the robot delivers the construction kits completely inside of the construction area. Partial points are awarded if the construction kits are not completely inside of the construction area. If **a shuttle no longer touches** its start area (grey square) or **is damaged no points** will be awarded for the construction kit completely or partially inside the construction area, teams **will still score points for the element touching the game mat**.

4.8 Don't damage the constructed habitats

Four constructed habitats are placed on the game mat. The ball on top of these elements must not touch the game mat. Points are awarded for each ball remaining on a pedestal base when the robot run has finished. The pedestal bases are allowed to be moved outside of their starting areas as long as the ball does not touch the game mat full points will be awarded.

4.9 Robot Finish

The robot must finish with parts of the robot projecting/touching the start/finish area. The robot only **needs to project into** this area for points to be scored. The robot does not need to have attempted all mission tasks for these points to be scored. Some positive points must be scored these do not include the points for the ultra-sonic sensor, colour sensor or the bonus points for the constructed habitats. Finishing points are only awarded if the robot is projecting into or stopped inside of the start area when the robot has stopped moving.

Explorer Prime Scoring

For Explorer Prime game elements are awarded full points if the elements **is completely inside** the correct scoring area, if part of the element is outside of the scoring area and is touching the game mat the team may not be awarded point for the element, **unless stated otherwise** in the game rules and on the score sheet.

Completely inside means that no part of the element is touching outside of the scoring area.

5. Scoresheet

Explorer Prime -						
Tasks	Each	Points	Score 1	Score 2	Score 3	Score 4
Ultrasonic Sensor Used to start the robot.	Yes / No	20				
Used a light sensor to follow a line.	Yes / No	30				
Excavators completely on Martian Soil. (no other images excavators are upright)	0 1 2	20 each (Max 40)				
Water pipe kit completely inside the water pipe construction area.	Yes / No	20				
Algae tank completely inside the algae refill zone. (Algae tank is upright)	Yes / No	20				
Titanium and gold ore deposits Award points based on the conditions of each individual ore element. Completely = No part of the ore element is touching the border of the scoring area.						
Titanium ore completely inside the refinery area.	0 1 2 3 4 5	10 each (Max 50)				
Gold ore completely inside the refinery area.	0 1 2 3	20 each (Max 60)				
Construction kits and shuttles						
Construction kit touching the game mat.	0 1 2	10 each (Max 20)				
Construction kit completely inside the construction area. (shuttle touches starting position and is not damaged)	0 1 2	40 each (Max 80)				
Construction kit partially inside the construction area. (shuttle touches starting position and is not damaged)	0 1 2	20 each				
Bonus Points						
Hydrogen tank not moved from starting position.	Yes / No	10				
Constructed habitat undamaged (balls not touching the game mat)	0 1 2 3 4	5 each (Max 20)				
Robot projecting into the start area.	Yes / No	30				
<div style="display: flex; justify-content: space-around; align-items: center;"> <div style="border: 1px solid black; padding: 5px; text-align: center;">Bronze 0-89 points</div> <div style="border: 1px solid black; padding: 5px; text-align: center;">Silver 90 - 199 points</div> <div style="border: 1px solid black; padding: 5px; text-align: center;">Gold 200 - 319 points</div> <div style="border: 1px solid black; padding: 5px; text-align: center;">Diamond 320+ points</div> </div>	TOTAL: (400 max)					
	TIME:					

6. Scoring Interpretation

The images in this section will help to explain the scoring options available to teams. In cases where scoring is unsure the judge must bias their decision to the best possible outcome of the team.

Robot start area

The robot must start completely inside the start/finish area. All parts of the robot must fit into this area **including robot cables**. No part of the robot is allowed to project outside of the start/finish area or into the surrounding line. The start/finish area is defined as the white area only and not the surrounding different colour line/square.

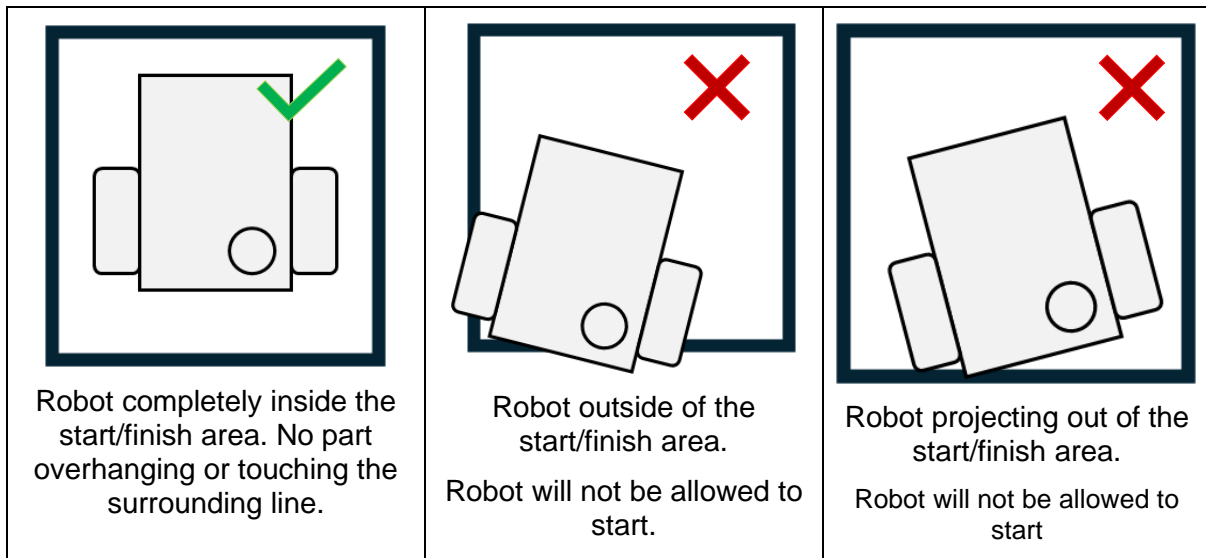

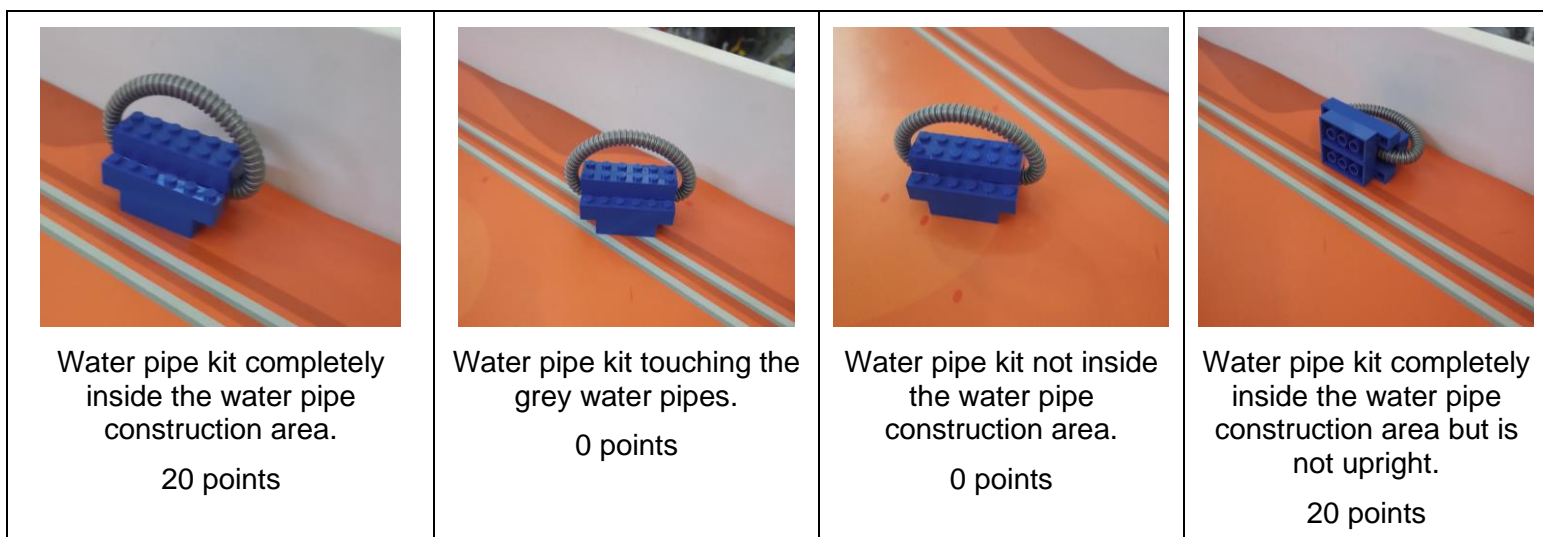

Water Pipe Kit:

The below images apply to the water pipe kit in the water pipe construction area.



Excavator Elements:

The below images apply to the excavator elements on Martian soil.

 <p>Excavator completely on Martian soil and is upright. 20 points</p>	 <p>Excavator not completely on Martian soil. 0 points</p>	 <p>Excavator completely on Martian soil but is not upright. 0 points</p>
---	--	--





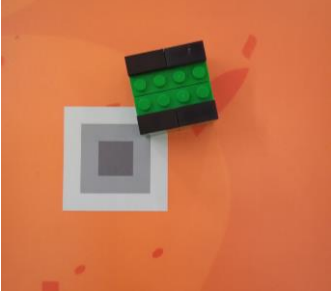
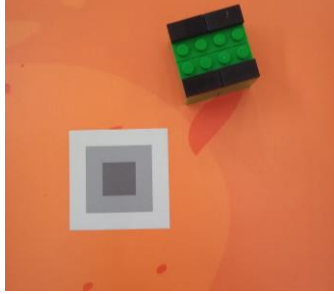

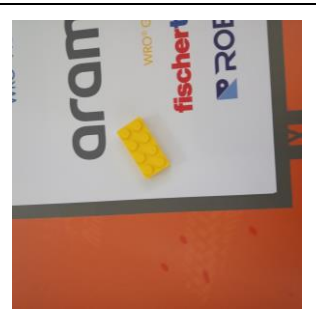

Hydrogen Tank

The below images apply to the hydrogen tank.

 <p>Hydrogen tank completely inside its starting area. 10 points</p>	 <p>Hydrogen tank moved and touching outside of the starting area. 0 points</p>	 <p>Hydrogen tank moved completely outside of its starting area. 0 points</p>
---	--	---



Ore Deposits:

The below images apply to the titanium and gold ore deposits in the refinery area.

			
<p>Gold ore placed completely inside the refinery area. 20 points</p>	<p>Gold ore partially inside the refinery area. 5 points</p>	<p>Gold ore not touching inside the refinery area. 0 points</p>	<p>Gold ore stacked one on top of the other. 40 points</p>
			
<p>Titanium ore placed completely inside the refinery area. 10 points</p>	<p>Titanium ore partially inside the refinery area. 5 points</p>	<p>Titanium ore not touching inside the refinery area. 0 points</p>	<p>Titanium ore not inside or touching the refinery area. 0 points</p>

Algae Tank:

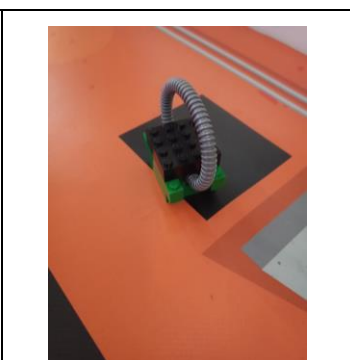
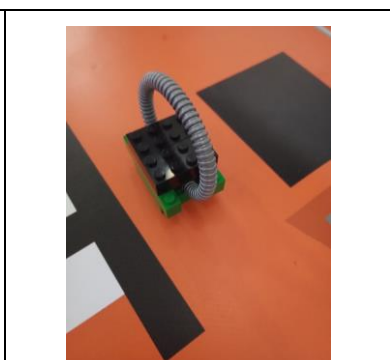
The below images apply for the algae tank in the algae refill zone.

			
<p>Algae tank completely inside the algae refill zone. 20 points</p>	<p>Algae tank partially inside the algae refill zone. 10 points</p>	<p>Algae tank not touching the algae refill zone. 0 points</p>	<p>Algae tank completely inside the algae refill zone but is not upright. 10 points</p>

Shuttles and Construction Kits

The below images apply to the red and white shuttles and the construction kits placed in the construction area. What applies for the red shuttle applies for the white shuttle as well.



Construction kit is touching the game mat.

10 points



Construction kit partially inside the construction area.

20 points

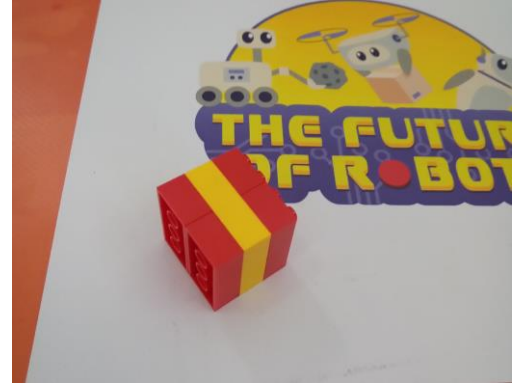

Construction kit completely inside the construction area.

40 points



Construction kit completely inside the construction area, the shuttle has been moved and still touches the grey starting square.

40 points



Construction kit completely inside the construction area but the shuttle has been moved outside of the grey starting square.

0 points

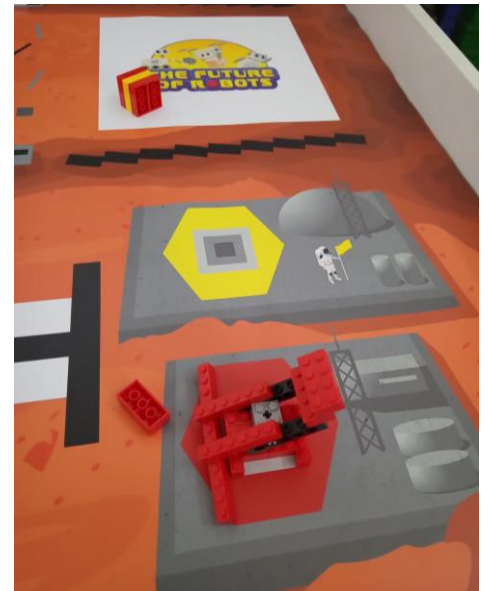

Construction kit completely inside the construction area but the shuttle is broken

0 points

Constructed Habitats

The below images apply to the four constructed habitats on the game mat.

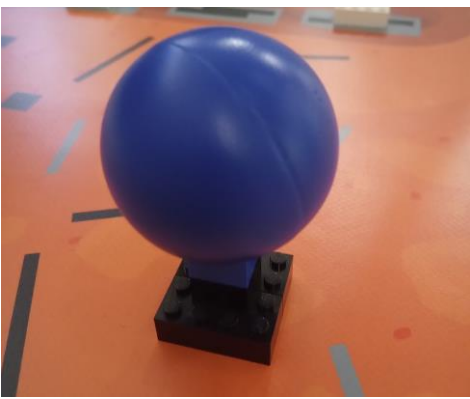
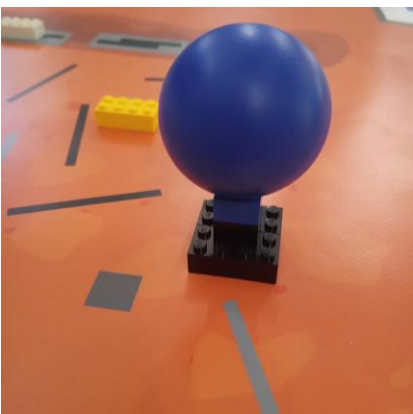
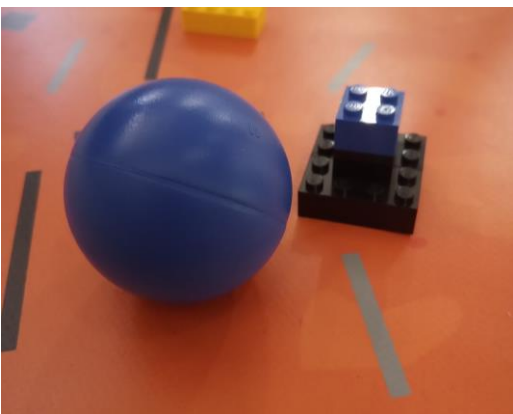
 <p>Constructed habitat with ball still on pedestal base 5 points</p>	 <p>Constructed habitat with ball still on pedestal base but the pedestal is not in its original starting position. 5 points</p>	 <p>Constructed habitat ball is touching the game mat 0 points</p>
---	---	---

Robot finishing points

The robot must finish with parts of the robot projecting into the start/finish area. The robot only needs to project into this area for points to be scored. The robot does not need to have attempted all mission tasks for these points to be scored. Some positive points must be scored these do not include the points for the ultra-sonic sensor or the bonus points.

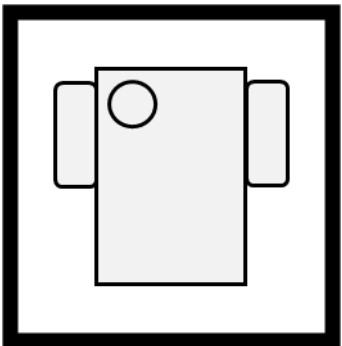
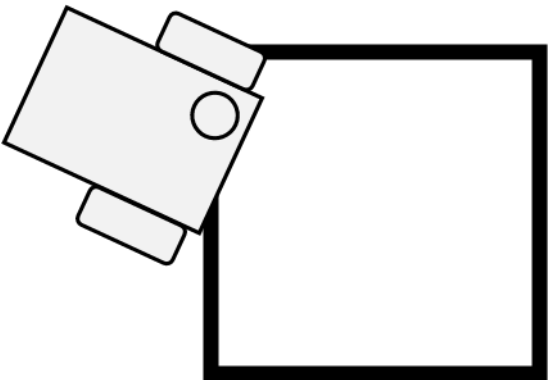
 <p>Robot completely inside the start/finish area. 30 points</p>	 <p>Robot projecting into the start/finish area 30 points</p>
---	---

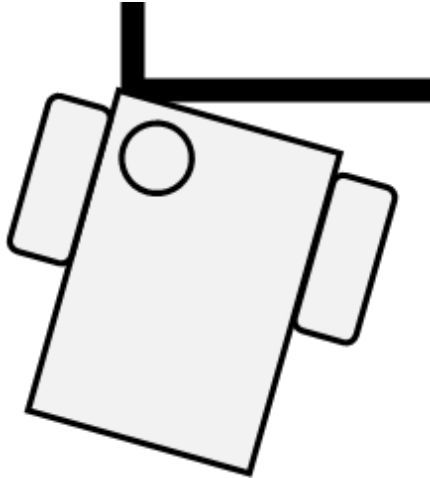

Robot not projecting into the start/finish area.

0 points

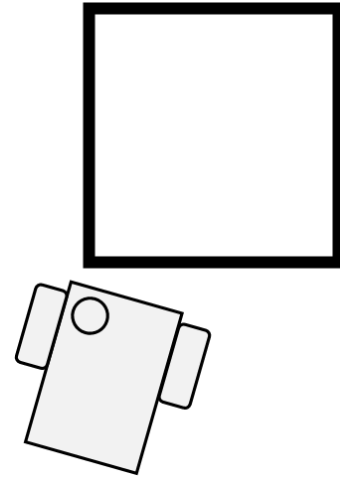

Robot not projecting into the start/finish area.

0 points

PART TWO – ASSEMBLY OF GAME OBJECTS

Excavators (x2)

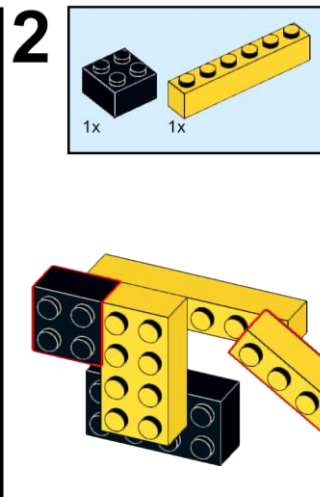
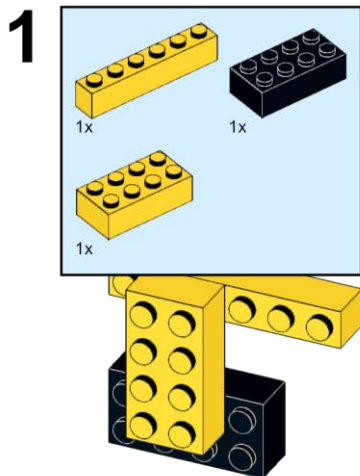
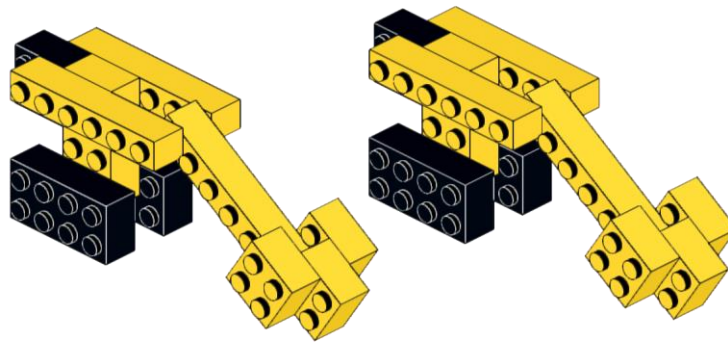
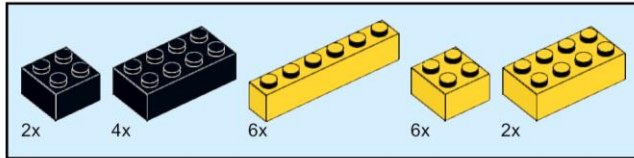

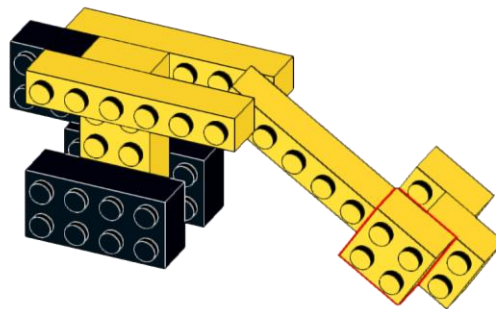
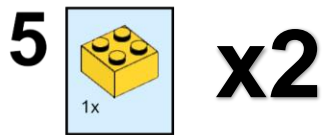
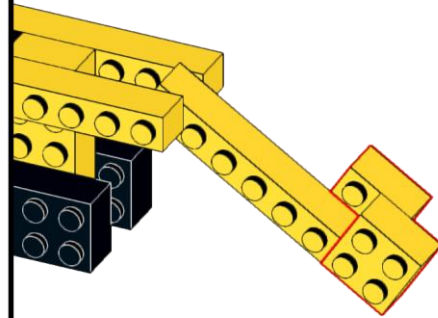
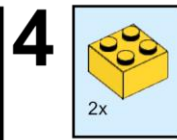
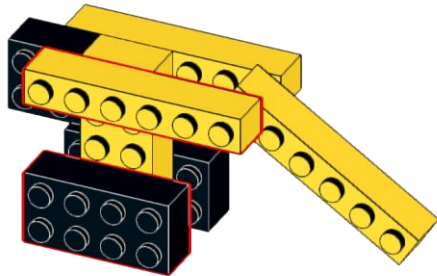
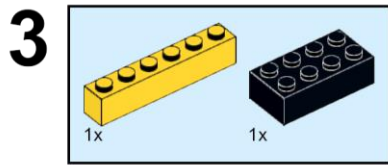

Shuttles & Construction Kits

x1 White, x1 Red

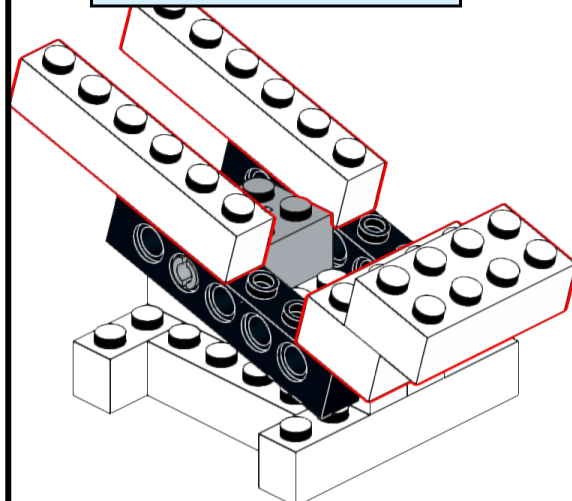
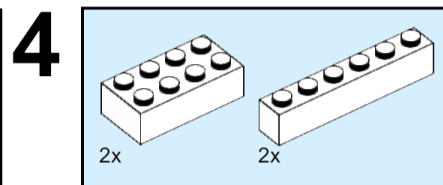
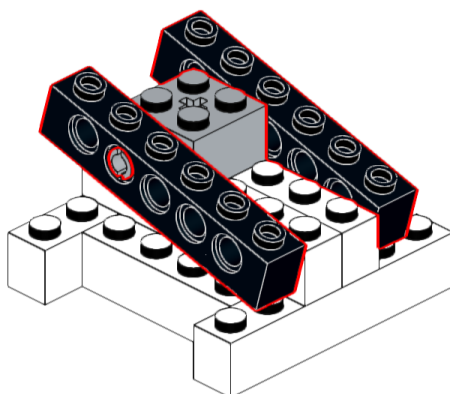
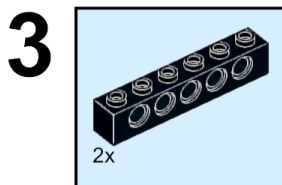
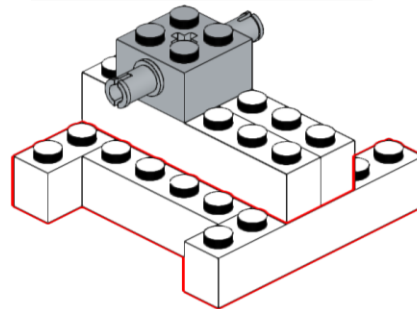
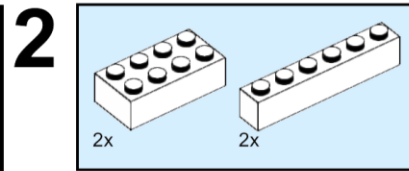
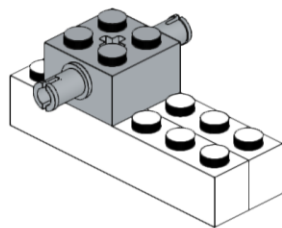
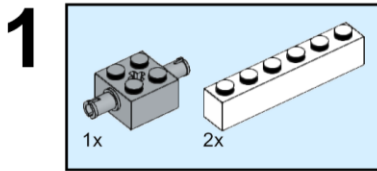
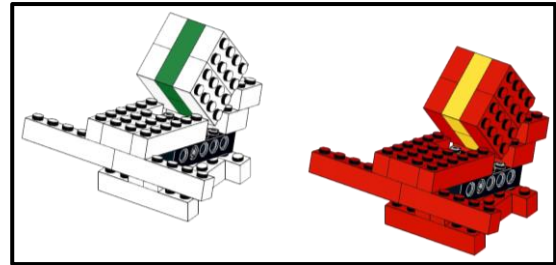

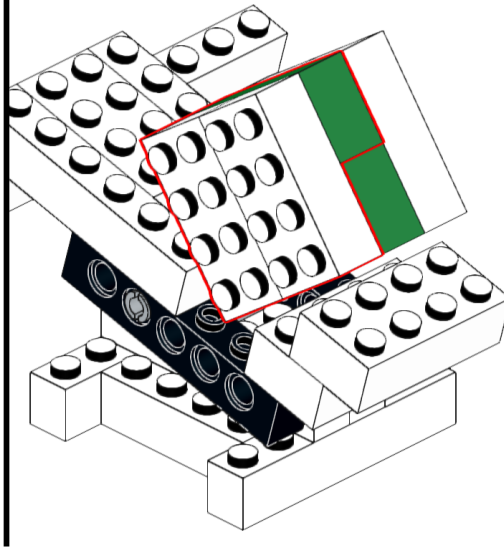
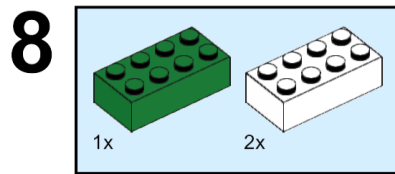
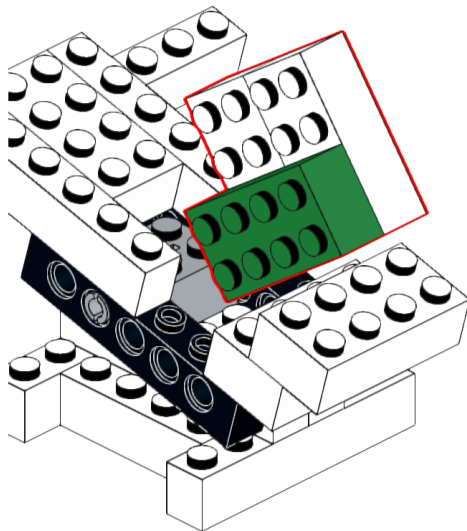
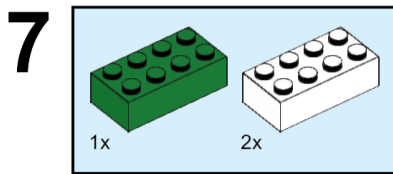
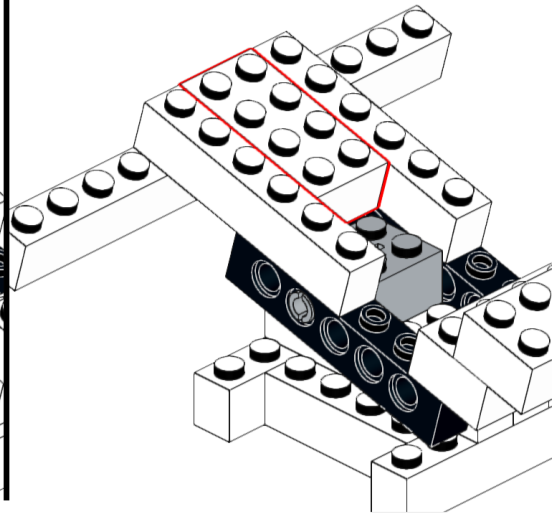
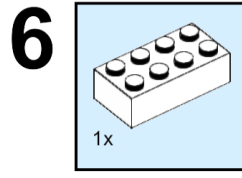
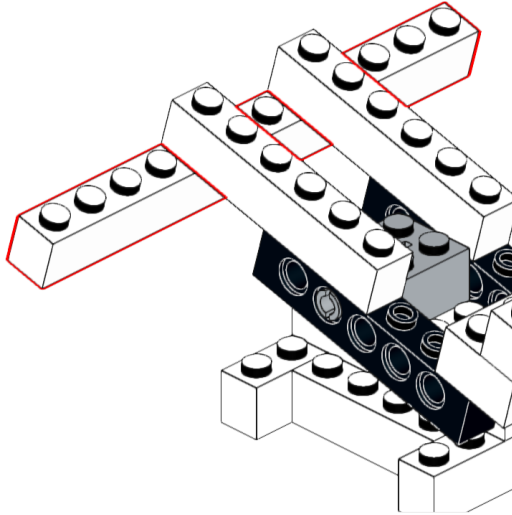
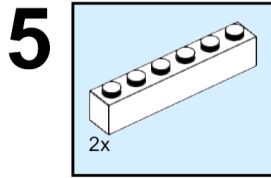

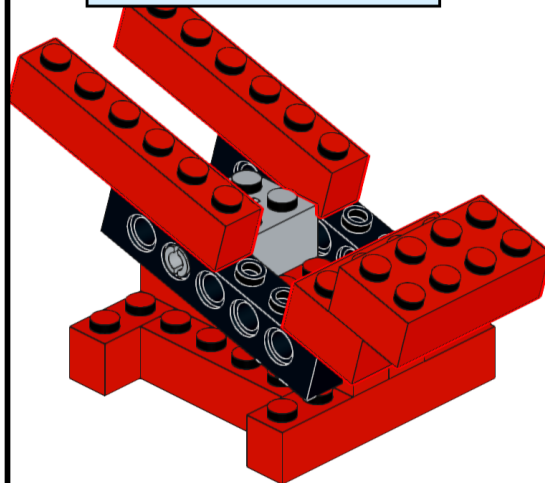
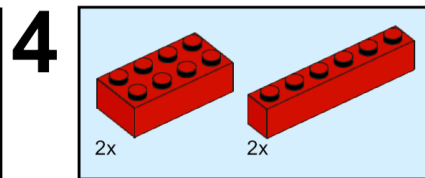
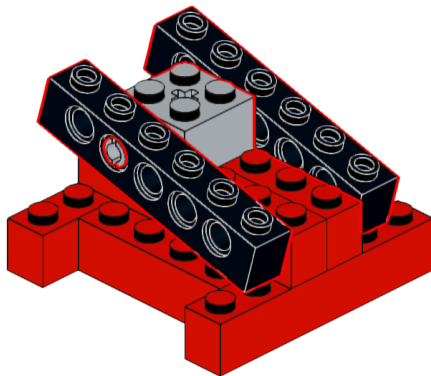
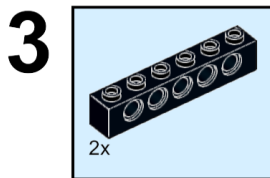
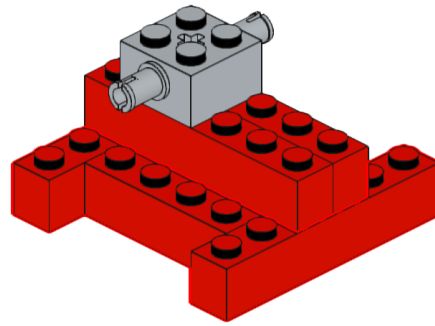
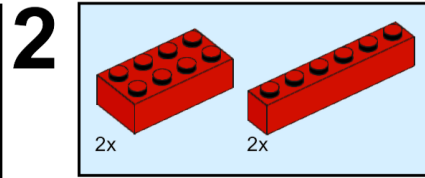
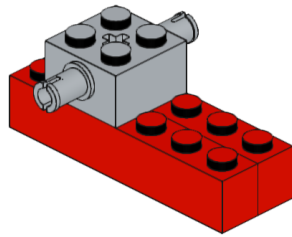
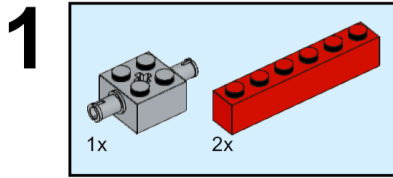

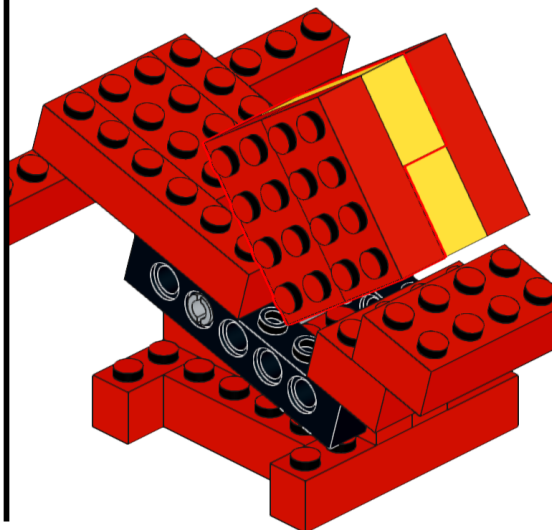
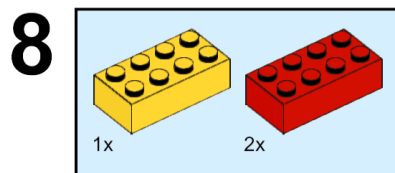
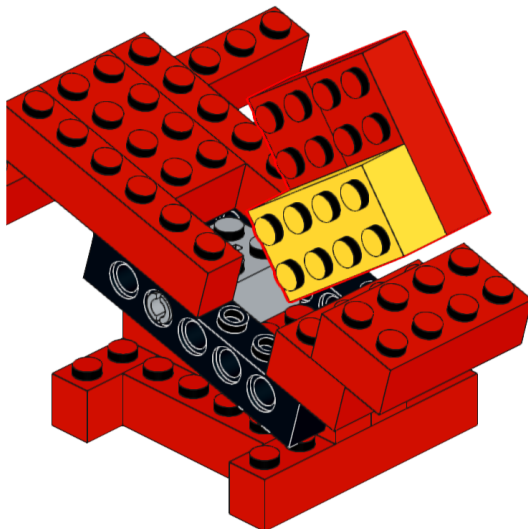
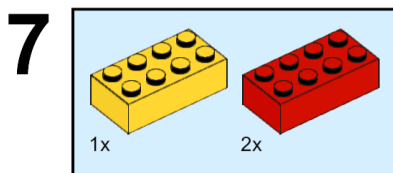
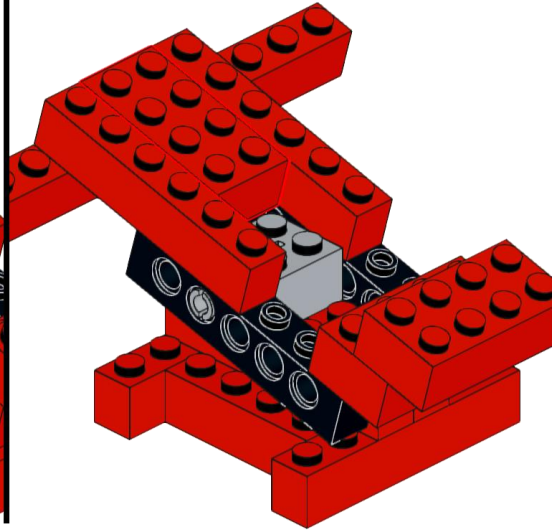
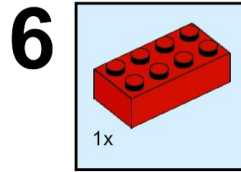
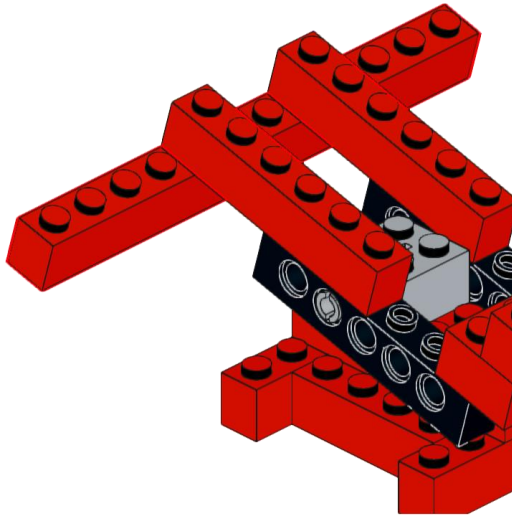
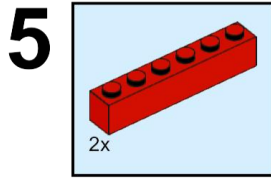

Algae Tank (x1) & Hydrogen Tank (x1)

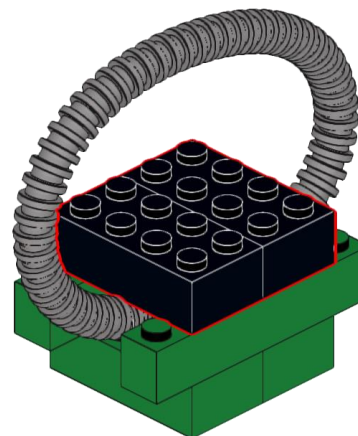
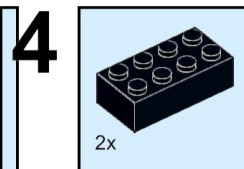
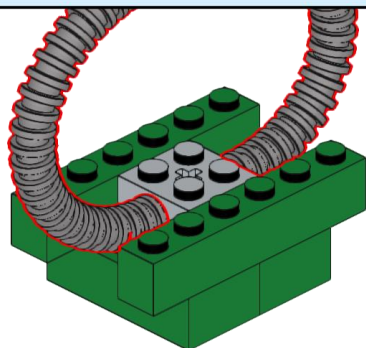
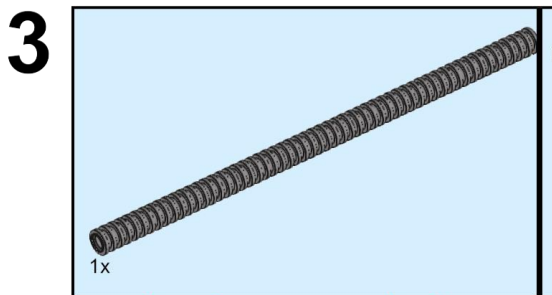
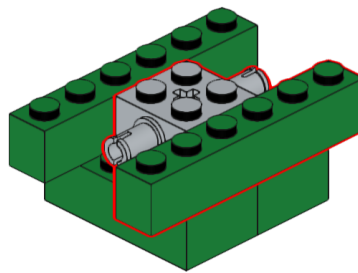
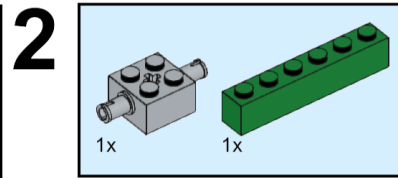
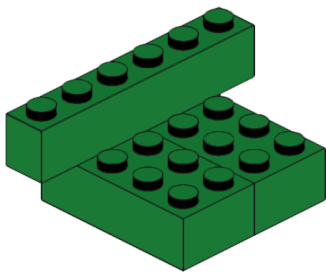
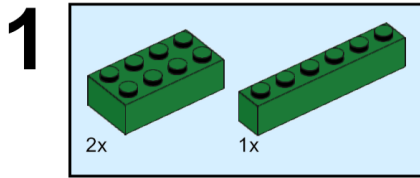
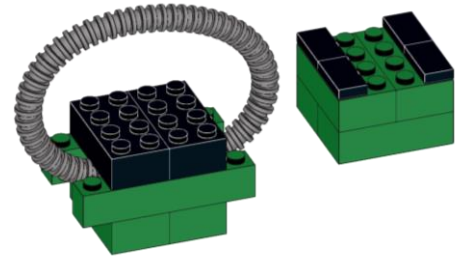

5

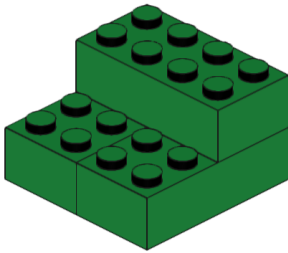
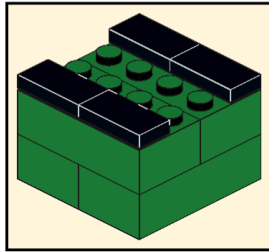
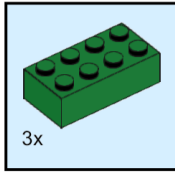

6

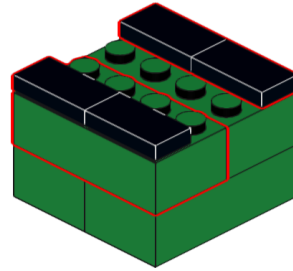
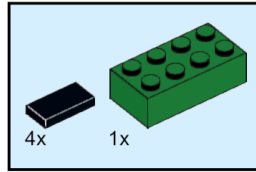

Water Pipe Kit (x1)

1

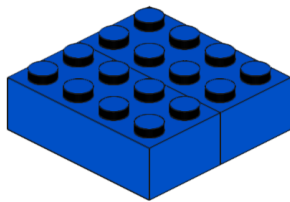
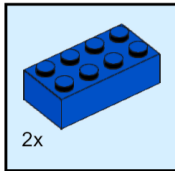

2

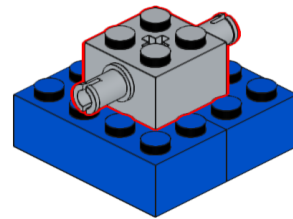
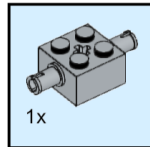

3

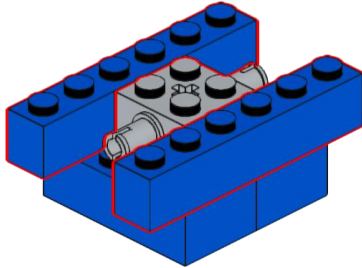
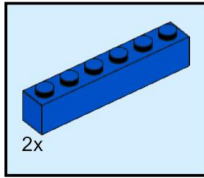

4

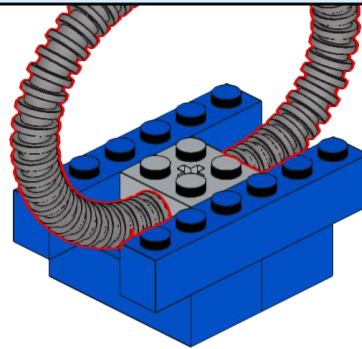
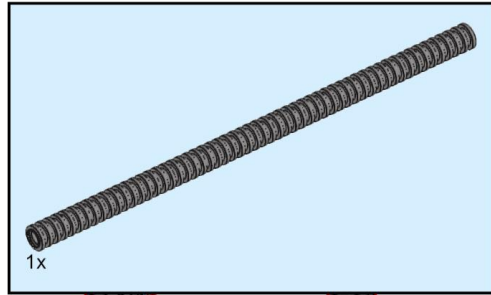

5

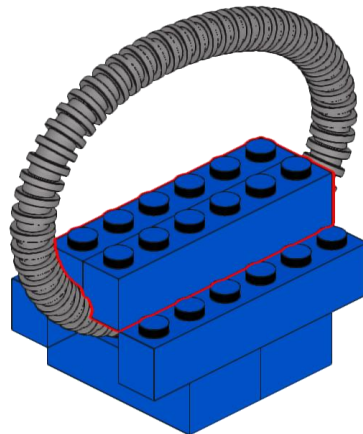
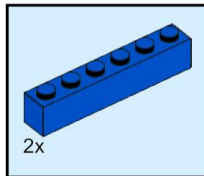

Titanium (x5) & Gold (x3) Ore Deposits

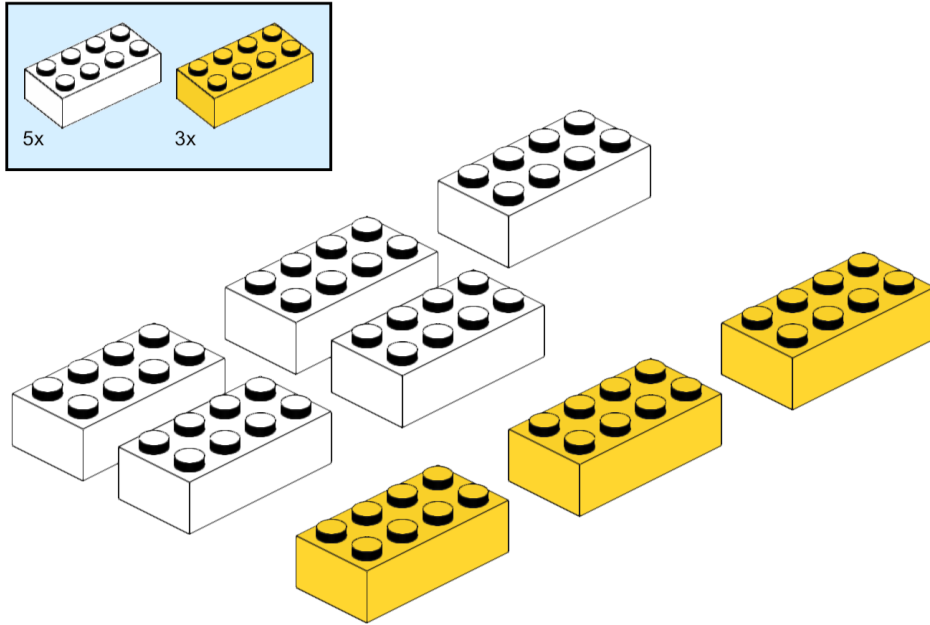

Constructed Habitats x2 red and x2 blue

